



iwis Spike chains for the thermoform industry

iwis Specialist Precision Conveyor Chains

Our conveyor chains are developed to suit customer specific requirements and applications. They can be manufactured using standard components or specially developed products. With this in mind we present our uniquely developed **Thermoform** chains which are used throughout the world, offering precision, quality and longevity of life in all thermoformed packaging applications.

Product highlights:

- 1 Specially designed guide roller and wear resistant studs offer precise film alignment.
- 2 SL (super longlife) heat-treated, easy break pins increase wearlife and precision of operation.
- 3 Uniquely designed and specially hardened spike profiles offer the best solution for handling your Thermoform material and optimises the lifespan of the chain.
- 4 Uniquely developed intermediate plate reduces lateral forces within the chain, thus reducing elongation and extending wear life.

iwis offers a wide variety of conveyor chains

iwis conveyor chains can be customized to meet the specific requirements of your application. iwis not only offers a wide range of special straight and bent attachment plates, we can also help customers develop their own special designs.

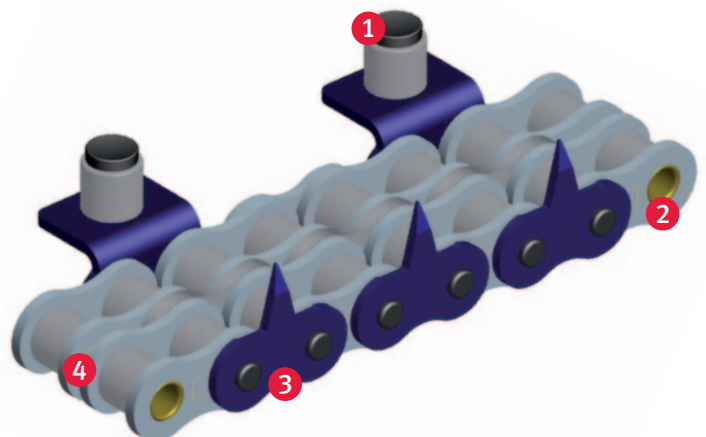

For more information, contact us:

iwis antriebssysteme GmbH & Co. KG / Albert-Roßhaupter-Straße 53 / 81369 Munich, Germany
Phone: +49 89 76909-1600 / Fax: +49 89 76909-1198 / eMail: sales@iwis.com

www.iwis.com

iwis® Spike roller chains

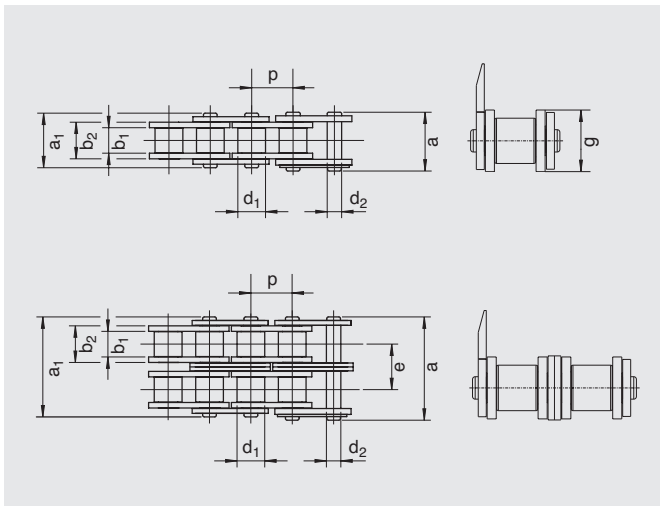

Available standard roller chains according to DIN:

DIN ISO	Ref. no. iwis	Pitch p (")	Pitch p (mm)	Breaking load F_B			Weight/m q (kg/m)	Inner link			Outer link		Roller d_1 (mm) max.	Pin d_2 (mm) max.	Transverse pitch e (mm)
				iwis (N) ave.	Norm (N) min.	Bearing area f (cm ²)		b_1 (mm) min.	b_2 (mm) max.	g (mm) max.	a_1 (mm) max.	a (mm) max.			
08 B-1	L 85 SL	1/2 x 5/16"	12,70	22.000	18.000	0,50	0,70	7,75	11,30	11,80	16,90	18,50	8,51	4,45	-
08 B-2	D 85 SL	1/2"	12,70	40.000	32.000	1,00	1,35	7,75	11,30	12,20	30,80	32,40	8,51	4,45	13,92

Examples of available special straight attachments plates:

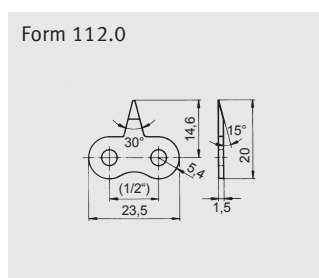

FL85SL with 112.0:
Art. 50002138

FD85SL with 112.0:
Art. 50018836

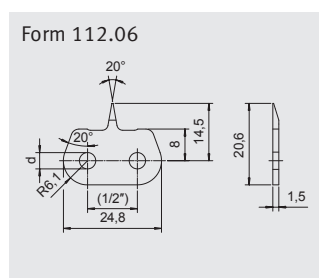

FD85SL with 112.06:
Art. 50019757

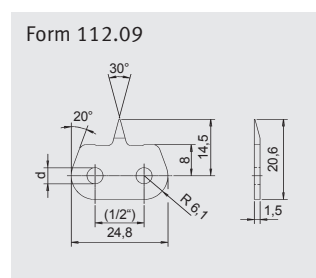

FD85SL with 112.09:
Art. 50028230

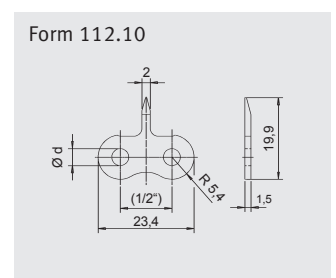

Further product benefits:

- Special lubrication available on request
- Reduced length tolerances
- Special chain solutions on request (e.g. with or without guide roller)
- MEGAlife maintenance free, ANSI and side bow versions available on request

For more information, contact us:

iwis antriebssysteme GmbH & Co. KG / Albert-Roßhaupter-Straße 53 / 81369 Munich, Germany
Phone: +49 89 76909-1600 / Fax: +49 89 76909-1198 / eMail: sales@iwis.com

www.iwis.com